

1. MAXIMUM PANEL THICKNESS = 6.10 [.240]
2. USE INSTRUCTION SHEET 408-1914-03
- ③ THIS PART NUMBER IS RESTRICTED, SEE SEPARATE DRAWING
- ④ SPECIAL PACKAGING
- ⑤ SUPERSEDED BY 225398-1
- ⑥ SUPERSEDED BY 225398-2
- ⑦ SUPERSEDED BY 413771-5

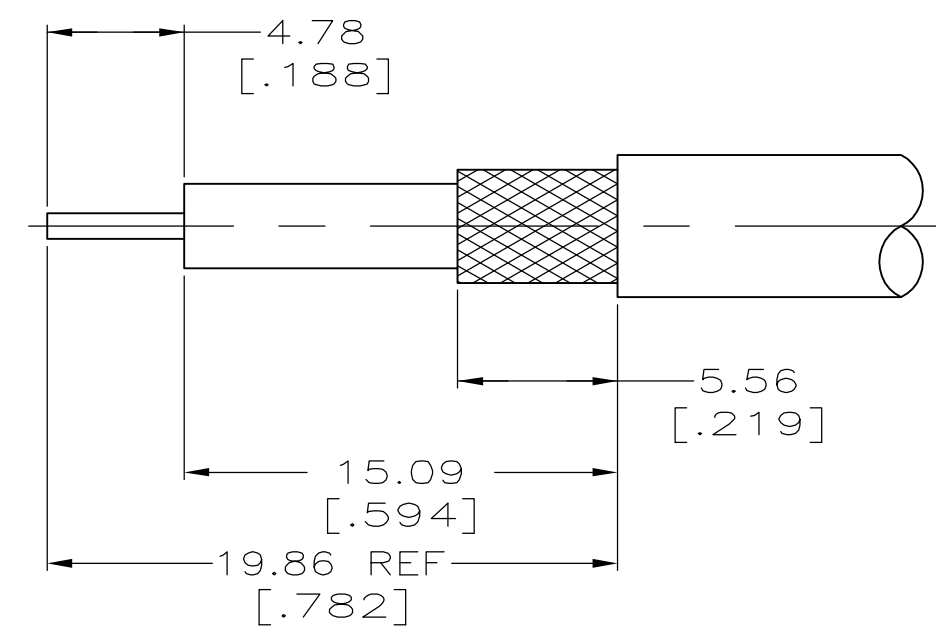

RECOMMENDED PANEL CUTOUT

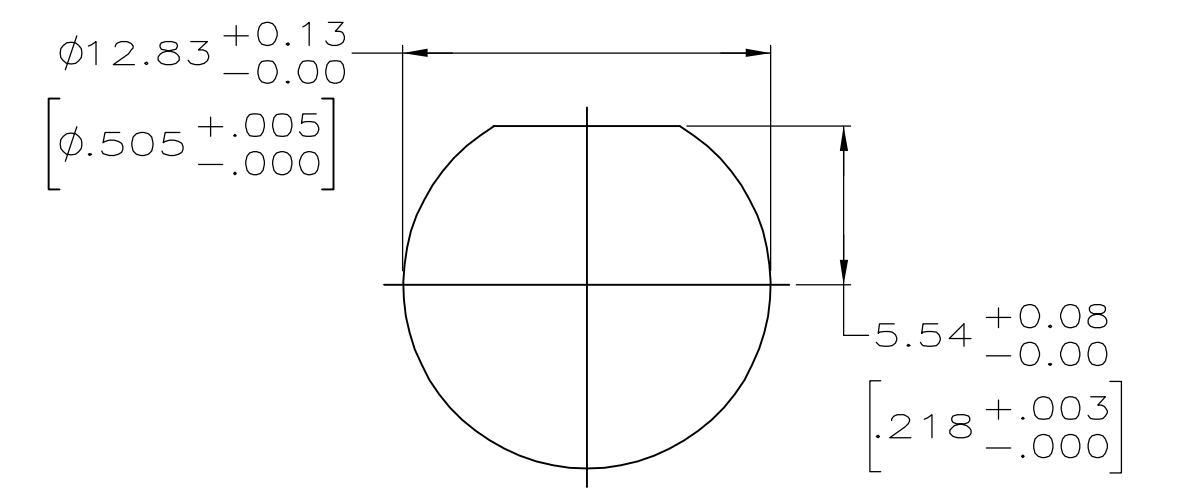

RECOMMENDED PANEL CUTOUT

OBSOLETE	-	34.93	[1.375]	RG-174/U & 188/U	.582 OZ	220009-1	21427-4	1-329631-2	1-329632-2	329633	9-328666-0	1-331368-2	1-331786-6	9-225398-2
OBSOLETE	-	38.10	[1.500]	RG-142/U,142A/U & 142B/U	-	220189-3	-	1-329631-2	1-329632-2	329633	9-225382-0	1-331369-7	1-331786-4	9-225398-1
OBSOLETE	-	34.93	[1.375]	RG-58/U,58A/U,58B/U & 58C/U	.582 OZ	69478-1	-	1-329631-2	1-329632-2	329633	9-50427-1	1-331369-6	1-331786-4	9-225398-0
OBSOLETE	④	34.93	[1.375]	RD-316 DOUBLE BRAIDED	-	69477-2	21427-4	1-329631-2	1-329632-2	329633	9-329049-0	1-331368-2	1-331786-6	2-225398-0
	⑥	34.93	[1.375]	-	-	-	-	-	-	-	-	-	-	1-225398-9
	③	34.93	[1.375]	-	-	-	-	-	-	-	-	-	-	1-225398-8
OBSOLETE	-	34.93	[1.375]	DEARBORN RG-62/U	.568 OZ	69477-1	-	1-329631-2	1-329632-2	329633	9-50428-1	2-331368-3	1-331786-5	1-225398-7
	-	34.93	[1.375]	RD-316 DOUBLE BRAIDED	-	69477-2	21427-4	1-329631-2	1-329632-2	329633	9-329049-0	1-331368-2	1-331786-6	1-225398-5
OBSOLETE	-	34.93	[1.375]	RG-188A/U DOUBLE SHIELD THERMATICS A74 71A	-	69477-2	21427-4	1-329631-2	1-329632-2	329633	9-329049-0	1-331368-2	1-331786-6	1-225398-4
OBSOLETE	-	34.93	[1.375]	RAYCHEM 7524A1312	.558 OZ	69477-1	-	1-329631-2	1-329632-2	329633	9-329461-0	2-331368-1	1-331786-6	1-225398-3
OBSOLETE	-	34.93	[1.375]	TIMES FM-59	-	69477-1	-	1-329631-2	1-329632-2	329633	9-50428-0	2-331368-1	1-331786-5	1-225398-2
OBSOLETE	-	34.93	[1.375]	AMPHENOL 21-597	.558 OZ	69477-2	-	1-329631-2	1-329632-2	329633	9-329461-0	1-331368-2	1-331786-6	1-225398-0
	④	34.93	[1.375]	RG-180/U,180A/U & 195/U	.558 OZ	69477-2	-	1-329631-2	1-329632-2	329633	9-329461-0	1-331368-4	1-331786-6	225398-9
	-	34.93	[1.375]	RG-179/U & 187/U CABLE	.557 OZ	220009-1	21427-4	1-329631-2	1-329632-2	329633	9-328666-0	1-331368-4	1-331786-6	225398-8
	-	34.93	[1.375]	RG-174/U & 188/U	.582 OZ	220009-1	21427-4	1-329631-2	1-329632-2	329633	9-328666-0	1-331368-2	1-331786-6	225398-7
	-	38.10	[1.500]	RG-142/U,142A/U & 142B/U	-	220189-3	-	1-329631-2	1-329632-2	329633	9-225382-0	1-331369-7	1-331786-4	225398-6
OBSOLETE	-	34.93	[1.375]	RG-141/U & 141A/U	-	69478-1	-	1-329631-2	1-329632-2	329633	9-50427-1	1-331369-7	1-331786-4	225398-5
	-	38.10	[1.500]	RG55/U,55A/U,55B/U & 223/U	.568 OZ	69478-1	-	1-329631-2	1-329632-2	329633	9-225382-0	1-331369-6	1-331786-4	225398-3
OBSOLETE	-	34.93	[1.375]	RG-59/U,59A/U,59B/U,62/U,62A/U & 62B/U	.582 OZ	69477-1	-	1-329631-2	1-329632-2	329633	9-50428-0	2-331368-3	1-331786-5	225398-2
	-	34.93	[1.375]	RG-58/U,58A/U,58B/U & 58C/U	.582 OZ	69478-1	-	1-329631-2	1-329632-2	329633	9-50427-1	1-331369-6	1-331786-4	225398-1

NOTES	L	CABLE	WEIGHT	CRIMP TOOL	⑦ BUSHING QTY=1	⑥ JAM NUT QTY=1	⑤ LOCK WASHER QTY=1	④ GASKET QTY=1	③ FERRULE QTY=1	② CONTACT QTY=1	① JACK ASSEMBLY QTY=1	PART NUMBER
-------	---	-------	--------	------------	--------------------	--------------------	------------------------	-------------------	--------------------	--------------------	--------------------------	-------------

THIS DRAWING IS A CONTROLLED DOCUMENT.

DIMENSIONS: mm [INCHES]	TOLERANCES UNLESS OTHERWISE SPECIFIED:	DWN J. KURTZ 2/21/90	tyco Electronics	Tyco Electronics Corporation Harrisburg, PA 17105-3608
0 PLC ± -	1 PLC ± -	CHK J. KURTZ 2/21/90	NAME R. F. RUTH	JACK, BULKHEAD, BNC
2 PLC ± 0.41 [.016]	3 PLC ± -	APVD R. F. RUTH	PRODUCT SPEC	
4 PLC ± -	ANGLES ± -	APPLICATION SPEC		
MATERIAL	FINISH	SIZE A1	CAGE CODE 00779	DRAWING NO 225398
		WEIGHT		RESTRICTED TO
		CUSTOMER DRAWING	SCALE 4:1	SHEET 1 of 1